

EMI FILTERS “C” TYPE

Hermetic C-Section Broadband Filter

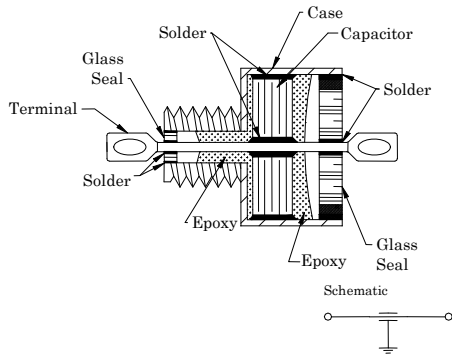

BROADBAND

Potted C-Section Broadband

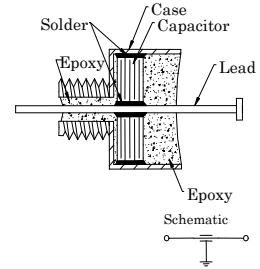

FEATURES:

- QPL to MIL-F-28861/1.
- Fully environmentally protected.
- Thread bushing intended for bulkhead mounting.
- Solder coated terminals.
- High capacitance values for excellent insertion loss.
- Tin-lead, silver, or gold plating.

APPLICATIONS:

Lower cut-off frequency requirements along with higher voltage ratings dictate the use of relatively larger size broadband style filters. The high density monolithic multilayer discoidal capacitor is the basic element in PA&E's broadband "C" type feed-thru's. All parts listed throughout this section of the catalog utilize exclusively, ceramic material with dielectric constant (K) of 1700 and temperature characteristic of X7R or BX. A "C" section is the simple single element feed-thru filter suitable for applications in which source and load impedances are relatively high and moderate insertion loss curve slope of 20 dB / decade is satisfactory. Although the series inductance of this three terminal device is minimized due to its mechanical configuration, resonant dips are to be expected between 10-50 MHz, depending on the size and capacitance values. It should be noted that at increasing capacitance the cut-off frequency (3dB point) decreases and insertion loss gradient is not affected.

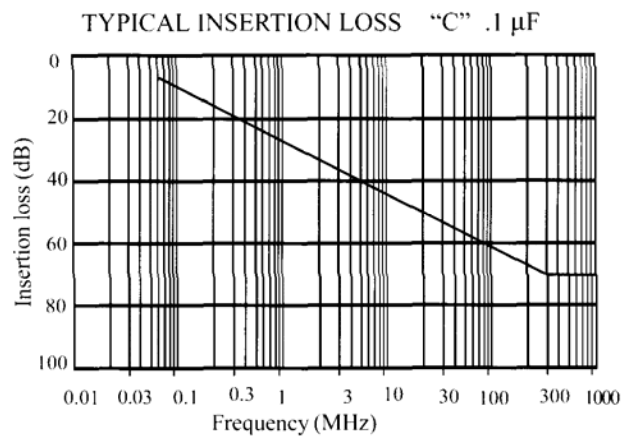
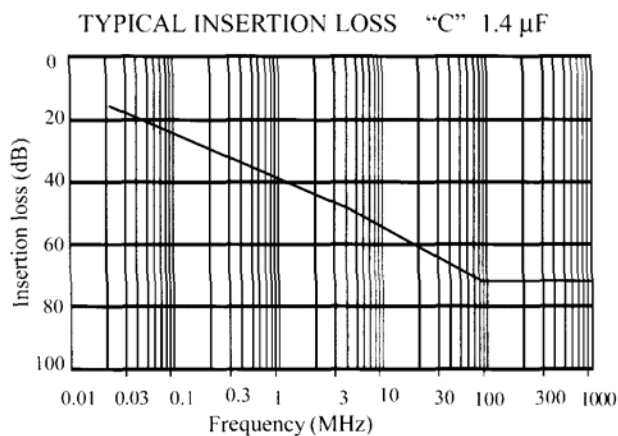

BROADBAND

EMI FILTERS “C” TYPE

GENERAL SPECIFICATIONS

| | |
|----------------------------------|--|
| Capacitance / Tolerance: | Measured @ 1 KHz and .1-1 Vrms, 25°C / -0% +100% |
| Dissipation Factor: | 2.5% max @ 1 KHz and .1-1 Vrms, 25°C |
| Insulation Resistance: | 100 GΩ or 1000 MΩ -mF, whichever is less @ 25°C, WVDC |
| Working Voltage: | 50 VDC to 400 VDC and 125 to 240 VAC, 400Hz |
| Dielectric Withstanding Voltage: | 250 % of WVDC min. @ 25°C for 5±1 sec, 50 mA max chg. Current |
| Volt-Temperature Limit: | +10% -30% @ WVDC and -55°C to +125°C |
| Current Rating: | 10 Amp and 15 Amp |
| DC Resistance: | .005Ω max. |
| Insertion Loss: | Measured per Mil-STD-220, IL between any two adjacent specified frequencies shall be that of the lower of the two frequencies in order to accommodate resonant dips. |
| Operating Temperature: | -55°C to +125°C |
| Storage Temperature: | -65°C to +150°C |
| Materials: Case | Brass, ½ hard per QQ-B-626 (composition #22) or CRS Iron-nickel alloy (alloy 52) per ASTM F-30 |
| Terminals | |
| Finish: Case | Silver per QQ-S-365 / Gold or Tin-Lead Optional |
| Terminals | Silver per QQ-S-365 / Gold or Tin-Lead Optional |
| Applicable MIL Specifications: | Mil-F-28861 / Mil-F-15733 / Mil-C-83439 |
| Environmental Test Spec: | Mil-STD-202 |
| Thermal Shock: | Method 107, Condition A except step 3 @ 125°C |
| Immersion: | Method 104, Condition A (Hermetic devices only) |
| Salt Spray: | Method 101, Condition B |
| Moisture Resistance: | Method 106 (Hermetic devices only) |
| Barometric Pressure: | Method 105, Condition B |
| Resistance to Soldering Heat: | Method 210, Condition B |
| Seal: | Method 112, Condition A / Hermetically sealed parts only |
| Vibration: | Method 204, Condition D |
| Shock: | Method 213, Condition I |
| Terminal Strength: | Method 211, Condition A |
| Solderability: | Method 208 |
| Life: | Method 108, Condition D |

Marking per Mil-STD-130

Filter body size permitting:

PA&E logo

PA&E part number

Date code

INSTALLATION GUIDE

Although PA&E filters are rugged with excellent resistance to physical damage, good working practices should be utilized in the installation process to avoid possible post-installation problems.

1) Maximum recommended mounting torque should be applied to the nut only and observed as follows:

| | | | | | | | |
|--------------|------------|------------|------------|--------------|--------------|--------------|--------------|
| Thread size | 0-80 | 2-56 | 4-40 UNC | 8-32 UNC | 12-32 UNC | 1/4-28 UNF | 5/16-24 UNF |
| Mount torque | 10 in. oz. | 18 in. oz. | 3 in. lbs. | 3-5 in. lbs. | 6-8 in. lbs. | 7-9 in. lbs. | 7-9 in. lbs. |

2) Avoid bending or flexing terminals at the point of exit from the glass or epoxy seal to preserve the integrity of the seal and/or ceramic capacitor.

3) Solder connections to the terminals should be performed with temperatures not exceeding 230°C, placing a heat sink between soldering point and filter body whenever possible.

EMI FILTERS "C" TYPE

BROADBAND

Potted C-Section Broadband Filter

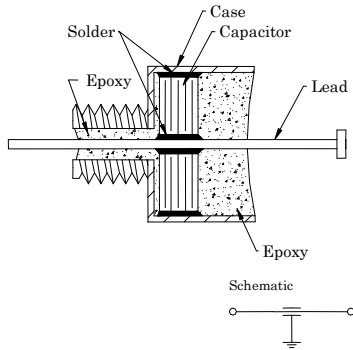

Hermetic C-Section Broadband Filter

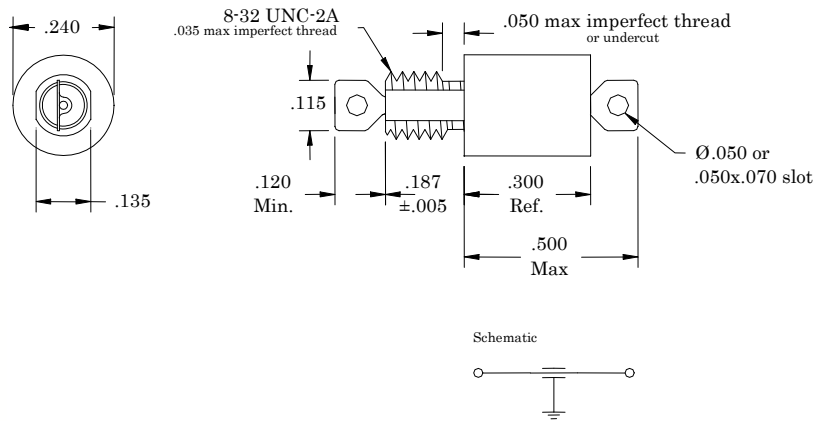

TOLERANCES: ± .010 AND AS NOTED.

| PA&E FILTERS PART NUMBER | WORKING VOLTAGE (VDC) | I _{dc} (A) | MIN CAP (μF) | MIN IR (MΩ) | MAX R _{dc} (MΩ) | MINIMUM INSERTION LOSS (dB) Per Mil-STD-220 | | | | | | | |
|--------------------------------|-----------------------------|------------------------|--------------------|-------------------|--------------------------------|--|------------|------------|------------|----------|-----------|------------|----------|
| | | | | | | 30 KHz | 100 KHz | 150 KHz | 300 KHz | 1 MHz | 10 MHz | 100 MHz | 1 GHz |
| 3116-6643-394** | 50 | 10 | .39 | 2000 | .005 | 3 | 12 | 15 | 21 | 32 | 40 | 58 | 70 |
| 3126-6643-254** | 100 | 10 | .25 | 3000 | .005 | - | 10 | 13 | 19 | 30 | 40 | 56 | 70 |
| 3136-6643-104** | 200 | 10 | .1 | 5000 | .005 | - | 5 | 8 | 13 | 22 | 38 | 50 | 70 |
| 3136-6643-753** | 200 | 10 | .075 | 10000 | .005 | - | - | - | 8 | 18 | 37 | 46 | 65 |
| 3136-6643-503** | 200 | 10 | .05 | 10000 | .005 | - | - | - | 3 | 15 | 34 | 45 | 60 |
| 3136-6643-253** | 200 | 10 | .025 | 10000 | .005 | - | - | - | - | 10 | 30 | 40 | 55 |
| 3166-6643-103** | 300 | 10 | .01 | 10000 | .005 | - | - | - | - | 4 | 20 | 35 | 50 |

Details subject to change without notice.

** PART NUMBERS ARE INCOMPLETE. PLEASE SEE PAGE 49 TO COMPLETE THE NUMBERS.

BROADBAND

EMI FILTERS "C" TYPE

Epoxy Seal C-Section Broadband Filter

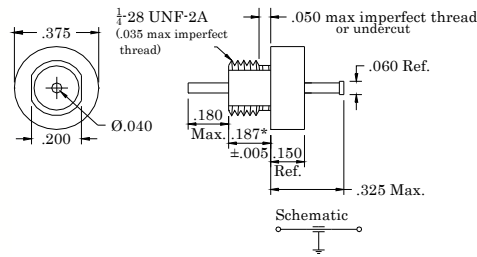

FOR .312 THREAD LENGTH, SUBSTITUTE 7 FOR 6 IN THE SEVENTH DIGIT OF THE PART NUMBER
TOLERANCES: ± .010 AND AS NOTED

| PA&E FILTERS PART NUMBER | WORKING VOLTAGE (VDC) | I _{dc} (A) | MIN CAP (μF) | MIN IR (MΩ) | MAX Rdc (MΩ) | MINIMUM INSERTION LOSS (dB) Per Mil-STD-220 | | | | | | | |
|--------------------------|-----------------------|---------------------|--------------|-------------|--------------|--|---------|---------|---------|-------|--------|---------|-------|
| | | | | | | 30 KHz | 100 KHz | 150 KHz | 300 KHz | 1 MHz | 10 MHz | 100 MHz | 1 GHz |
| 3118-7466-145** | 50 | 15 | 1.4 | 500 | .005 | 15 | 25 | 28 | 34 | 42 | 44 | 70 | 70 |
| 3118-7466-125** | 50 | 15 | 1.2 | 500 | .005 | 13 | 23 | 26 | 31 | 40 | 42 | 70 | 70 |
| 3128-7466-754** | 70 | 15 | .75 | 1000 | .005 | 8 | 19 | 22 | 28 | 38 | 40 | 64 | 70 |
| 3128-7466-504** | 70 | 15 | .5 | 2000 | .005 | 4 | 14 | 17 | 23 | 34 | 40 | 60 | 70 |
| 3128-7466-304** | 100 | 15 | .3 | 3000 | .005 | - | 12 | 15 | 20 | 30 | 40 | 56 | 70 |
| 3128-7466-154** | 100 | 15 | .15 | 5000 | .005 | - | 6 | 9 | 14 | 25 | 38 | 52 | 70 |
| 3138-7466-104** | 200 | 15 | .1 | 10000 | .005 | - | 5 | 8 | 13 | 22 | 38 | 50 | 70 |
| 3138-7466-503** | 200 | 15 | .05 | 10000 | .005 | - | - | - | 3 | 15 | 34 | 45 | 60 |
| 3168-7466-253** | 300 | 15 | .025 | 10000 | .005 | - | - | - | - | 10 | 30 | 40 | 55 |

Hermetic C-Section Broadband Filter

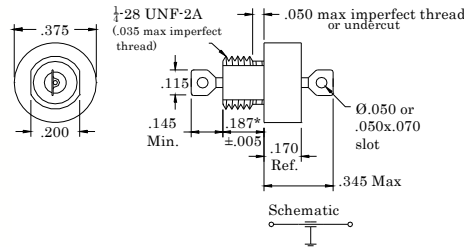

FOR .312 THREAD LENGTH, SUBSTITUTE 7 FOR 6 IN THE SEVENTH DIGIT OF THE PART NUMBER
TOLERANCES: ± .010 AND AS NOTED

| PA&E FILTERS PART NUMBER | WORKING VOLTAGE (VDC) | I _{dc} (A) | MIN CAP (μF) | MIN IR (MΩ) | MAX Rdc (MΩ) | MINIMUM INSERTION LOSS (dB) Per Mil-STD-220 | | | | | | | |
|--------------------------|-----------------------|---------------------|--------------|-------------|--------------|--|---------|---------|---------|-------|--------|---------|-------|
| | | | | | | 30 KHz | 100 KHz | 150 KHz | 300 KHz | 1 MHz | 10 MHz | 100 MHz | 1 GHz |
| 3118-7563-145** | 50 | 15 | 1.4 | 500 | .005 | 15 | 25 | 28 | 34 | 42 | 44 | 70 | 70 |
| 3118-7563-125** | 50 | 15 | 1.2 | 500 | .005 | 13 | 23 | 26 | 31 | 40 | 42 | 70 | 70 |
| 3128-7563-754** | 70 | 15 | .75 | 1000 | .005 | 8 | 19 | 22 | 28 | 38 | 40 | 64 | 70 |
| 3128-7563-504** | 70 | 15 | .5 | 2000 | .005 | 4 | 14 | 17 | 23 | 34 | 40 | 60 | 70 |
| 3128-7563-304** | 100 | 15 | .3 | 3000 | .005 | - | 12 | 15 | 20 | 30 | 40 | 56 | 70 |
| 3128-7563-154** | 100 | 15 | .15 | 5000 | .005 | - | 6 | 9 | 14 | 25 | 38 | 52 | 70 |
| 3138-7563-104** | 200 | 15 | .1 | 10000 | .005 | - | 5 | 8 | 13 | 22 | 38 | 50 | 70 |
| 3138-7563-503** | 200 | 15 | .05 | 10000 | .005 | - | - | - | 3 | 15 | 34 | 45 | 60 |
| 3168-7563-253** | 300 | 15 | .025 | 10000 | .005 | - | - | - | - | 10 | 30 | 40 | 55 |

Details subject to change without notice.

** PART NUMBERS ARE INCOMPLETE. PLEASE SEE PAGE 49 TO COMPLETE THE NUMBERS.

EMI FILTERS "C" TYPE

BROADBAND

Hermetic C-Section Broadband Filter

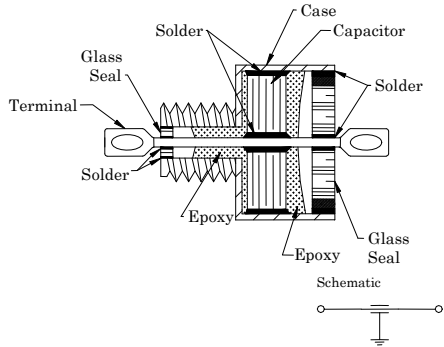

Hermetic C-Section Broadband Filter

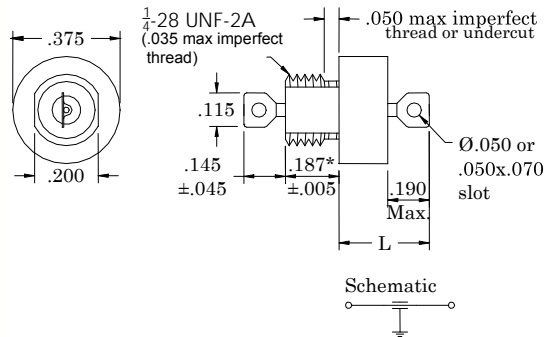

FOR .312 THREAD LENGTH, SUBSTITUTE 7 FOR 6 IN THE SEVENTH DIGIT OF THE PART NUMBER
TOLERANCES: ± .010 AND AS NOTED.

| PA&E FILTERS PART NUMBER | L MAX (in.) | WORKING VOLTAGE (VDC) | I _{dc} (A) | MIN CAP (μF) | MIN IR (MΩ) | MAX Rdc (MΩ) | MINIMUM INSERTION LOSS (dB) Per Mil-STD-220 | | | | | | | |
|--------------------------------|-------------------|-----------------------------|------------------------|--------------------|-------------------|--------------------|--|------------|------------|------------|----------|-----------|------------|----------|
| | | | | | | | 30 KHz | 100 KHz | 150 KHz | 300 KHz | 1 MHz | 10 MHz | 100 MHz | 1 GHz |
| 3118-7863-405** | .730 | 50 | 15 | 4.0 | 100 | .005 | 22 | 32 | 36 | 42 | 50 | 60 | 70 | 70 |
| 3118-7863-285** | .530 | 50 | 15 | 2.8 | 300 | .005 | 20 | 30 | 34 | 40 | 45 | 54 | 70 | 70 |
| 3118-7863-215** | .530 | 50 | 15 | 2.1 | 300 | .005 | 17 | 27 | 31 | 37 | 45 | 48 | 70 | 70 |
| 3118-7863-145** | .410 | 50 | 15 | 1.4 | 500 | .005 | 15 | 25 | 28 | 34 | 42 | 44 | 70 | 70 |
| 3128-7863-125** | .410 | 100 | 15 | 1.2 | 500 | .005 | 13 | 23 | 26 | 31 | 40 | 42 | 70 | 70 |
| 3128-7863-754** | .410 | 100 | 15 | .75 | 1000 | .005 | 8 | 19 | 22 | 28 | 38 | 40 | 64 | 70 |
| 3138-7863-504** | .410 | 200 | 15 | .5 | 2000 | .005 | 4 | 14 | 17 | 23 | 34 | 40 | 60 | 70 |
| 3138-7863-304** | .410 | 200 | 15 | .3 | 3000 | .005 | - | 12 | 15 | 20 | 30 | 40 | 56 | 70 |
| 3148-7863-154** | .410 | 115VAC | 15 | .15 | 5000 | .005 | - | 6 | 9 | 14 | 25 | 38 | 52 | 70 |

Details subject to change without notice.

** PART NUMBERS ARE INCOMPLETE. PLEASE SEE PAGE 49 TO COMPLETE THE NUMBERS.

BROADBAND

EMI FILTERS "C" TYPE

Hermetic C-Section Broadband Filter

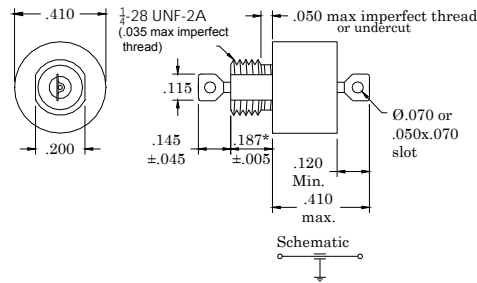

FOR .312 THREAD LENGTH, SUBSTITUTE 7 FOR 6 IN THE SEVENTH DIGIT OF THE PART NUMBER
TOLERANCES: ± .010 AND AS NOTED

| PA&E FILTERS PART NUMBER | L MAX (in.) | WORKING VOLTAGE (VDC) | I _{dc} (A) | MIN CAP (μF) | MIN IR (MΩ) | MAX R _{dc} (MΩ) | MINIMUM INSERTION LOSS (dB) Per Mil-STD-220 | | | | | | | |
|--------------------------|-------------|-----------------------|---------------------|--------------|-------------|--------------------------|--|---------|---------|---------|-------|--------|---------|-------|
| | | | | | | | 30 KHz | 100 KHz | 150 KHz | 300 KHz | 1 MHz | 10 MHz | 100 MHz | 1 GHz |
| 3118-8763-125** | .410 | 50 | 15 | 1.2 | 500 | .005 | 13 | 23 | 26 | 31 | 40 | 50 | 70 | 70 |
| 3128-8763-704** | .410 | 70 | 15 | .7 | 1000 | .005 | 8 | 19 | 22 | 28 | 38 | 45 | 64 | 70 |
| 3128-8763-454** | .410 | 100 | 15 | .45 | 2000 | .005 | 4 | 14 | 17 | 23 | 34 | 42 | 60 | 70 |
| 3138-8763-254** | .410 | 150 | 15 | .25 | 4000 | .005 | - | 9 | 12 | 18 | 29 | 40 | 56 | 70 |
| 3148-8763-154** | .410 | 125VAC | 15 | .15 | 5000 | .005 | - | 6 | 9 | 14 | 25 | 38 | 52 | 70 |
| 3168-8763-104** | .410 | 300 | 15 | .1 | 7000 | .005 | - | 5 | 8 | 13 | 22 | 38 | 50 | 70 |

Hermetic C-Section Broadband Filter

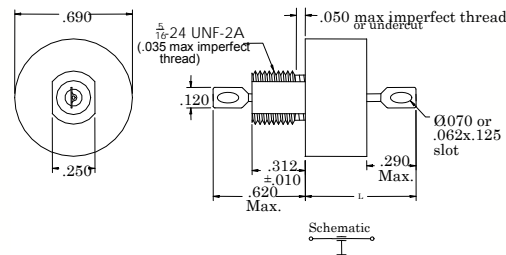

| PA&E FILTERS PART NUMBER | L MAX (in.) | WORKING VOLTAGE (VDC) | I _{dc} (A) | MIN CAP (μF) | MIN IR (MΩ) | MAX R _{dc} (MΩ) | MINIMUM INSERTION LOSS (dB) Per Mil-STD-220 | | | | | | | |
|--------------------------|-------------|-----------------------|---------------------|--------------|-------------|--------------------------|--|---------|---------|---------|-------|--------|---------|-------|
| | | | | | | | 30 KHz | 100 KHz | 150 KHz | 300 KHz | 1 MHz | 10 MHz | 100 MHz | 1 GHz |
| 3118-9E83-955** | .750 | 50 | 15 | 9.5 | 100 | .005 | 30 | 40 | 45 | 50 | 60 | 70 | 70 | 70 |
| 3118-9C83-475** | .650 | 50 | 15 | 4.7 | 100 | .005 | 25 | 35 | 40 | 45 | 55 | 65 | 70 | 70 |
| 3128-9C83-285** | .650 | 100 | 15 | 2.8 | 600 | .005 | 20 | 30 | 34 | 40 | 48 | 60 | 70 | 70 |
| 3138-9C83-145** | .650 | 200 | 15 | 1.4 | 500 | .005 | 15 | 25 | 28 | 34 | 42 | 52 | 70 | 70 |
| 3168-9C83-125** | .650 | 300 | 15 | 1.2 | 500 | .005 | 13 | 23 | 26 | 321 | 40 | 50 | 70 | 70 |
| 3168-9C83-904** | .650 | 300 | 15 | .9 | 1000 | .005 | 10 | 21 | 24 | 30 | 39 | 47 | 66 | 70 |
| 3168-9C83-754** | .650 | 300 | 15 | .75 | 1000 | .005 | 8 | 19 | 22 | 28 | 38 | 45 | 64 | 70 |
| 3108-9C83-454** | .650 | 400 | 15 | .45 | 2000 | .005 | 4 | 14 | 17 | 23 | 34 | 42 | 60 | 70 |
| 3148-9C83-304** | .650 | 115VAC | 15 | .3 | 3000 | .005 | - | 12 | 15 | 20 | 30 | 40 | 56 | 70 |
| 3158-9C83-154** | .650 | 240VAC | 15 | .15 | 5000 | .005 | - | 6 | 9 | 14 | 25 | 38 | 52 | 70 |

Details subject to change without notice.

** PART NUMBERS ARE INCOMPLETE. PLEASE SEE PAGE 49 TO COMPLETE THE NUMBERS.