

THESE PRODUCTS ARE SUBJECT TO THE INTERNATIONAL TRAFFIC IN ARMS REGULATIONS ("ITAR"), AND MAY NOT BE RESOLD, DIVERTED, TRANSFERRED, TRANSMITTED, OR OTHERWISE BE DISPOSED OF IN ANY OTHER COUNTRY, EITHER IN THEIR ORIGINAL FORM OR AFTER BEING INCORPORATED THROUGH AN INTERMEDIATE PROCESS INTO OTHER END ITEMS, WITHOUT THE PRIOR WRITTEN APPROVAL OF THE U.S. DEPARTMENT OF STATE. IN ADDITION, RELATED TECHNICAL DATA MAY NOT BE DISCLOSED, EXPORTED OR TRANSFERRED IN ANY MANNER TO ANY FOREIGN NATIONAL OR ANY FOREIGN COUNTRY WITHOUT PRIOR WRITTEN APPROVAL OF THE DIRECTORATE OF DEFENSE TRADE CONTROLS, U.S. DEPARTMENT OF STATE.

NOTES:

- HERMETIC LEAK RATE: LESS THAN OR EQUAL TO 1×10^{-9} CC/SEC He AT 1 ATM DIFFERENTIAL PRESSURE.
- NOMINAL IMPEDANCE: 50 OHMS.
- DIELECTRIC WITHSTANDING VOLTAGE: 500VAC RMS MIN. @ SEA LEVEL.
- INSULATION RESISTANCE: 5000 MEGOHMS MINIMUM.
- DESIGNED TO BE LASER WELDED TO ALUMINUM ALLOY 6061 HOUSING
- MATERIALS:
WELD FLANGE: 4000 SERIES ALUMINUM
CONTACT: KOVAR 1AW ASTM-F15 OR MIL-1-23011.
INSULATOR: 7070 CORNING GLASS OR EQUIVALENT.
GROUND SPRING: 1AW ASTM-A276 OR QQ-S-763.
- FINISH: PIN AND BODY
NICKEL PLATE: .000100/.000250 THICK.
GOLD PLATE: .000050/.000100 THICK.
- ORDERING INFORMATION:
PLEASE SPECIFY ACCORDING TO THE FOLLOWING:

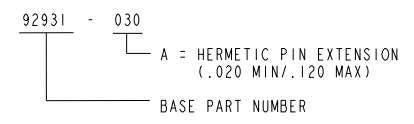

- $\varnothing .0276 \pm .0010$ THRU
- $\varnothing .038 \times 90^\circ \pm 5^\circ$
- $\varnothing .0995 \pm .0005 \nabla .240 \pm .002$
- $\varnothing .110 \times 90^\circ \pm 5^\circ$
- $\varnothing .315 \pm .001 \nabla .215 \pm .003$

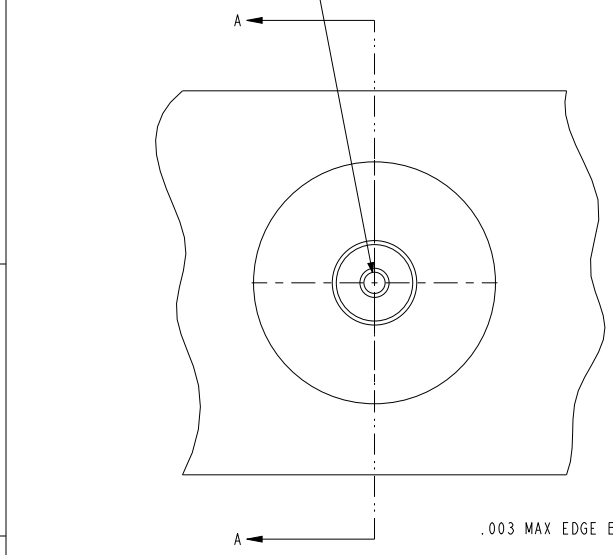

HOLE DETAIL B (WITH AIR DIELECTRIC) SCALE 4.000

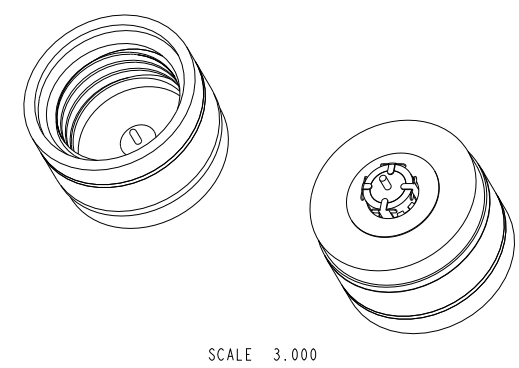
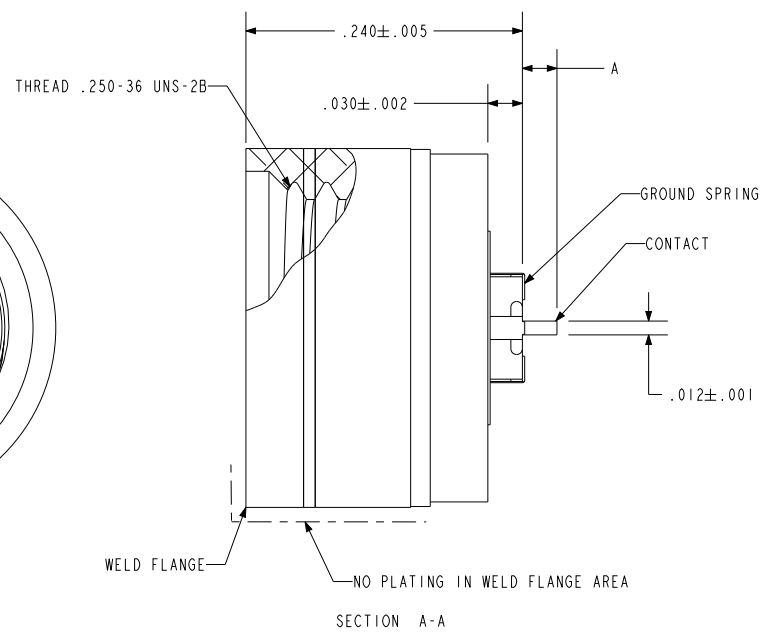
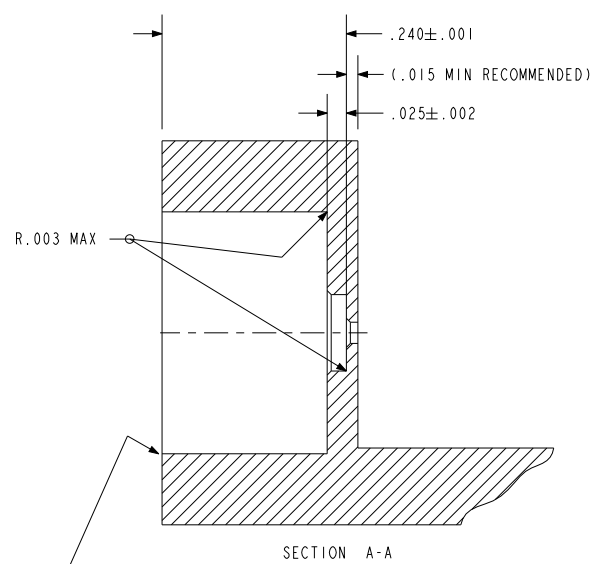
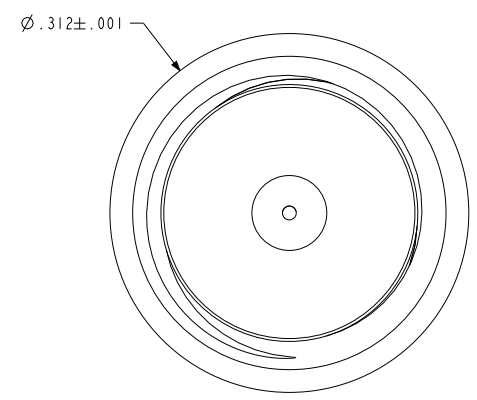

PACIFIC AEROSPACE & ELECTRONICS, INC.
434 Olds Station Rd. Wenatchee, Washington 98801
WWW.PACAERO.COM

TITLE: ALUMINUM LASER WELDABLE .012 FLANGE MOUNT RF CONNECTOR

VERSION: F.0 RELEASE DATE: 01-11-08

SHEET: 1 OF 1 DOCUMENT: 0-92931

CAGE CODE: 64567

THIRD ANGLE PROJECTION

pro/ENGINEER