

NOTES:

1. INTERFACE PER MIL-STD-348.
2. HERMETIC LEAK RATE: LESS THAN OR EQUAL TO 1×10^{-9} CC/SEC He AT 1 ATM DIFFERENTIAL PRESSURE.
3. NOMINAL IMPEDANCE: 50 OHMS.
4. DIELECTRIC WITHSTANDING VOLTAGE: 500VAC RMS MIN. @ SEA LEVEL.
5. INSULATION RESISTANCE: 5000 MEGOHMS MINIMUM.
6. DESIGNED TO BE LASER WELDED INTO TITANIUM HOUSINGS.
7. MATERIALS:
 WELD FLANGE: TITANIUM.
 FERRULE: Ni/Fe/Co (KOVAR) IAW ASTM-F15 OR MIL-I-23011.
 CONTACT: Ni/Fe/Co (KOVAR) IAW ASTM-F15 OR MIL-I-23011.
 INSULATOR: 7070 CORNING GLASS OR EQUIVALENT.
 GROUND SPRING: FULL HARD 302 S.ST. IAW ASTM-A276 OR 304L S.ST. IAW QQ-S-763.
8. FINISH: PIN, FERRULE AND SHELL
 NICKEL PLATE IAW QQ-N-290, .000100/.000250 THICK.
 GOLD PLATE IAW ASTM B488, TYPE I, CODE A, .000050/.000150 THICK.
9. ORDERING INFORMATION:
 PLEASE SPECIFY ACCORDING TO THE FOLLOWING:

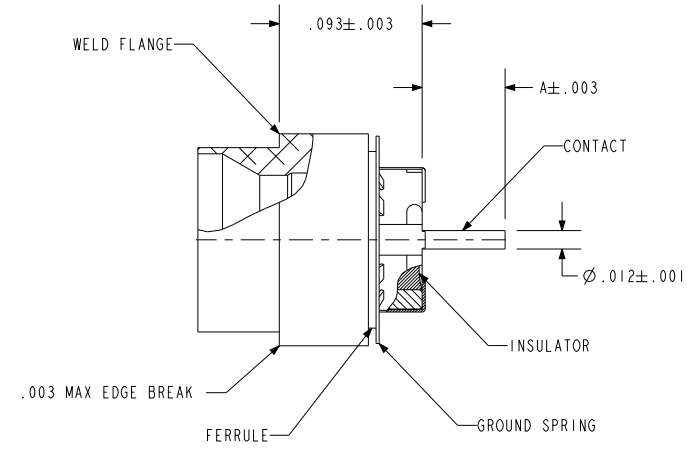

SECTION A-A

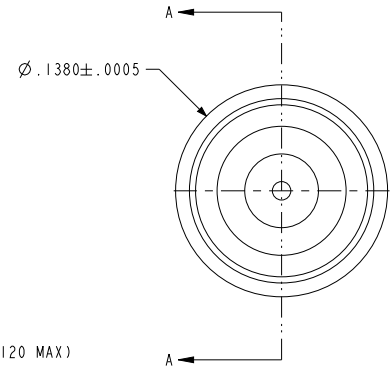
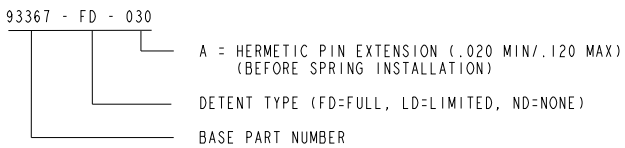
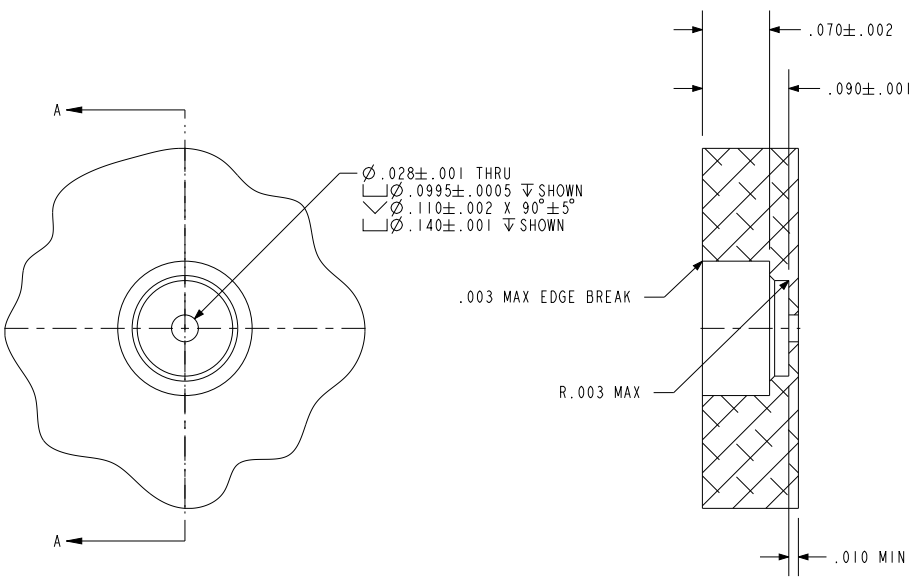

HOLE DETAIL
SCALE 5.000

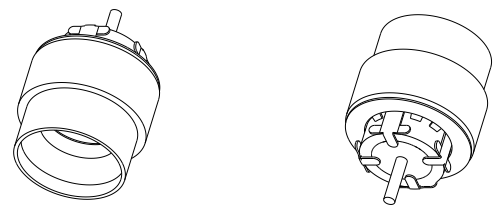

SCALE 5.000

PACIFIC AEROSPACE & ELECTRONICS, INC. 434 Olds Station Rd. Wenatchee, Washington 98801 WWW.PACAERO.COM	
TITLE: <h2 style="text-align: center;">CONNECTOR, LLWP, TITANIUM COMPATIBLE</h2>	THIRD ANGLE PROJECTION CAGE CODE: 64567 DOCUMENT: 0-93367
SALES DRAWING	SHEET: 1 OF 1 DOCUMENT: 0-93367
VERSION: D.0 RELEASE DATE: 01-05-11	pro/ENGINEER